

# ProTech<sup>®</sup>-GII

## Overspeed Protection Device

(Triple Modular Redundant)

### Description

The ProTech-GII is an overspeed safety device designed to safely shut down steam, gas, and hydro turbines of all sizes upon sensing an overspeed or over-acceleration event. This device accurately monitors turbine rotor speed and acceleration via active or passive MPUs (magnetic pickups) and issues a shutdown command to the turbine's trip valve(s) or corresponding trip system.

Depending on the system design, the ProTech-GII can be purchased with two dual-redundant trip relay outputs using a 2-out-of-3 voted architecture, or with three independent non-voted trip relay outputs. Individual alarm relays, 4–20 mA speed readouts, and Modbus<sup>®</sup> \* communications make this overspeed device easy to integrate into any turbine safety system.

\*—Modbus is a trademark of Schneider Automation Inc.

The ProTech-GII is available in flush-mount models designed to be installed within a standard 24" (610 mm) cabinet front door, or models designed to be bulkhead mounted on a wall or skid near the turbine set. Designed for harsh environments when installed within an enclosure, this device has an ingress protection rating of IP56 (protected against dust and completely protected against jets of water of similar force to heavy seas).

Designed for high reliability, each ProTech-GII module (A, B, C), depending on the purchased model, accepts two high-voltage power inputs (90–240 Vac / 100–150 Vdc) or one high-voltage power input (90–240 Vac / 100–150 Vdc) and one low-voltage power input (18–32 Vdc). This design works on a high-signal-select basis, allowing the unit to fully operate with either or both power sources available.

### Applications

The ProTech-GII is designed to safely shut down steam, gas, and hydro turbines upon sensing a turbine overspeed or over-acceleration event. The device's 12 millisecond response time and 0.5 to 32 000 rpm speed range make it ideal for application on all types and sizes of turbines.

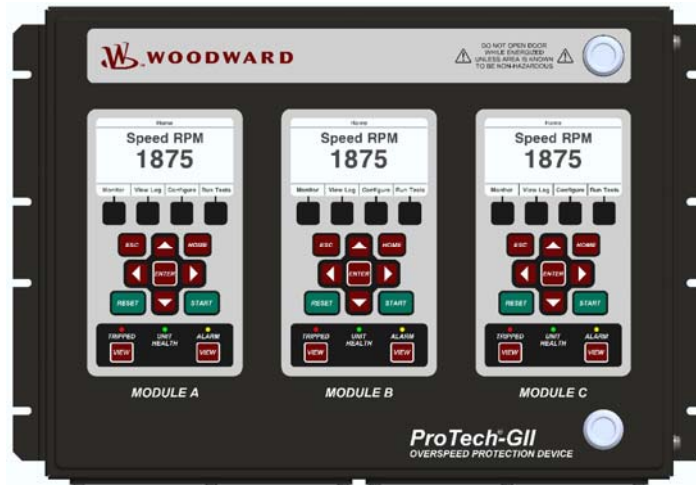

- IEC61508 SIL-3 Certified
- API670 & API612 Compliant
- 2-out-of-3 voting
- High availability (TMR)
- Acceleration protection
- On-line testing
- On-line repair
- Overspeed trip and test logs
- Modbus communications
- Password security protection
- 12 millisecond response time (independent voted output models)
- Internal frequency generator
- Optional Ethernet communication gateway

The ProTech-GII models with two dual-redundant relay outputs are design to be applied with simplex or dual-redundant trip block assemblies or trip systems. The ProTech-GII models with three independent non-voted output models are designed to be applied with special turbine trip block assemblies that perform the 2-out-of-3 voting within their design.

This fast acting overspeed protection device is designed to be applied in conjunction with a turbine control or trip system to safely shut down the turbine. Interface with related control systems or plant DCS(s) (Distributed Control Systems) can be performed via the ProTech-GII's redundant hard-wired input and output signals or through its triple-redundant serial Modbus communications ports. Optionally Ethernet gateways can be purchased to easily interface with plant Ethernet networks.

Certified as an IEC61508 SIL-3 (Safety Integrity Level Three) safety device, the ProTech-GII can easily be applied within an IEC61508 or IEC61511 based safety system. A thorough product manual is provided to instruct users on how to apply the ProTech-GII to meet IEC based requirements.

Designed for system-critical applications, the ProTech-GII's triple-modular architecture coupled with its on-line testing and on-line repair capabilities give it one of the highest availability and reliability ratings in the industry.

## Functionality

---

**On-line Testing**—Each ProTech-GII module can be tested manually from the module's front panel, Modbus communications port, or automatically via its auto-test routine function. The ProTech-GII allows users to configure an overspeed test to be performed automatically on a periodic basis, testing each module (A, B, C) one at a time, and logging the result of each test or halting the test for a sensed error.

**On-line Repair**—The ProTech-GII's triple-modular design allows users to easily replace one of its modules (A, B, C) while the turbine is on-line and operating normally. Ease of replacement is enhanced by the unit's backplane plug-and-operate structure, and its module-to-module learning function.

**Trip, Alarm, & Overspeed Logs**—The ProTech-GII log function logs (saves to memory) all trips, alarms, trip valve response times, and overspeed events. The trip-log function uses a scrolling buffer and records the last 50 sensed trip or alarm events and the last 20 overspeed events to memory, with associated times. Each log file can be viewed from the unit's front panel, or downloaded to a computer via the ProTech-GII service tool program. Each module utilizes non-volatile memory to ensure that all logged events are saved, even on loss of power.

**Real Time Clock**—Each ProTech-GII module utilizes a real-time clock to ensure accurate time logging. A special time-averaging function is utilized between modules to ensure module-to-module clock synchronization.

## Features

---

**Acceleration Detection**—Optionally the ProTech-GII can be configured to protect a turbine from high acceleration events also. The derivative of the speed signal is used to detect turbine acceleration and issue an associated trip command.

**MPU Detection**—Each module's speed sensor input uses special MPU open-wire detection circuitry to validate that the MPU is properly connected before turbine operation, and special loss-of-speed detection logic to validate MPU functionality during turbine operation.

**Automatic Overspeed Test Routine**—Optionally the ProTech-GII can be configured to routinely perform an overspeed test of each module, then log and report the test results. With this test routine, each module goes through its test sequence using an internal frequency generator to simulate an overspeed condition.

**Sulfur Contamination Resistant**—The ProTech-GII utilizes a special conformal coating material that has demonstrated excellent long-term protection against H<sub>2</sub>S and SO<sub>2</sub> gases at levels classified in international standard IEC 721-3-3 1994 - environment Class 3C2.

## Configurability

---

The ProTech-GII can be configured (programmed) through its front-panel keypad or via a software service tool operating on a site computer or laptop. For ease of use, all configuration settings, alarm/trip and overspeed logs are viewable via each module's high-resolution 4.2" (107 mm) color display. A special module-to-module learning function can be utilized to reduce configuration time and mistakes. Different levels of password security are utilized to protect unit configuration settings as well as limit access to device test functions.

## Installation Information

---

- Approximate dimensions, including faceplate: 330 x 445 x 159 mm (13 x 17.5 x 6.25")
- Depending on part number ordered, designed to be bulkhead mounted on a wall or skid, or flush-mounted vertically within a panel or cabinet
- Rated for IP56 (ingress protection level 5-6) based locations
- Operating / storage temperature range: -20 to +60 °C

## Input Signals

### Power Source (2 redundant)

- High Voltage Power Supply (88–264 Vac/47–63 Hz; 90–150 Vdc) @ 90 W
- Low Voltage Power Supply (18–32 Vdc) @ 100 W

### Speed Signals (1/module, 3 total)

Inputs can be configurable to accept signals from:

- MPUs (100–32 000 Hz) @ (1–35 Vrms)
- Proximity probes (0.5–25 000 Hz) @ 24 Vdc
- Gear Tooth Range (1–320 teeth)

### Discrete Inputs (3/module, 9 total)

- Alarm/Trip Reset Command
- Start Command
- Speed Fail Override Command

## Regulatory Compliance

### North American Compliance:

- **CSA:** CSA Certified for Class I, Division 2, Groups A, B, C, and D, T4 at 60 °C Ambient for use in Canada and the United States

### European Compliance:

- **EMC Directive:** 2004/108/EC
- **ATEX Directive:** 94/9/EC Zone 2, Category 3, Group II G, Ex nA II T4
- **WEEE Directive:** Exempt/Compliant as a component with 2002/96/EC of the European Parliament and of the Council of 27 January 2003 on waste electrical and electronic equipment (WEEE)
- **EuP Directive:** Exempt/Compliant from 2009/125/EC of the European Parliament and of the Council of 21 October 2009 establishing a framework for the setting of ecodesign requirements for energy-related products

### Other International Compliance:

- **TÜV:** TÜV certified for SIL-3 per IEC 61508 Parts 1-7, Function Safety of Electrical / Electronic / Programmable Electronic Safety Related Systems
- **C-Tick:** Declared to Australian Radiocommunications Act of 1992 and the New Zealand Radiocommunications Act of 1989.
- **GOST R:** Certified for use in explosive atmospheres within the Russian Federation per GOST R Certificate POCC US.ГБ04.В01594 with marking ExnAIICT4GcX

### Other Compliance:

- **IEC60068-2-60:** 1995 Part 2.60 Methods 1 and 4 (conformal coating)
- **API670, API612, & API611** compliant
- **RoHS Exempt** per Annex IA of Directive 2002/96/EC referring to "monitoring and control instruments" within the meaning of Category 9

## Output Signals

### Discrete Output Relays

#### Voted Relay Models

- Shutdown relay output (2 total, 2-out-of-3 voted)
  - Rated for 8 A @ 220 Vac or 8 A @ 24 Vdc
- Alarm relay output (1/module, 3 total)
  - Rated for 2 A @ 24 Vdc

### 4–20 mA Analog Output (1/module, 3 total)

- Dedicated to function as a speed meter readout

### Communication Ports (1/module, 3 total)

- Serial RS-232, RS-422, RS-485 Modbus port

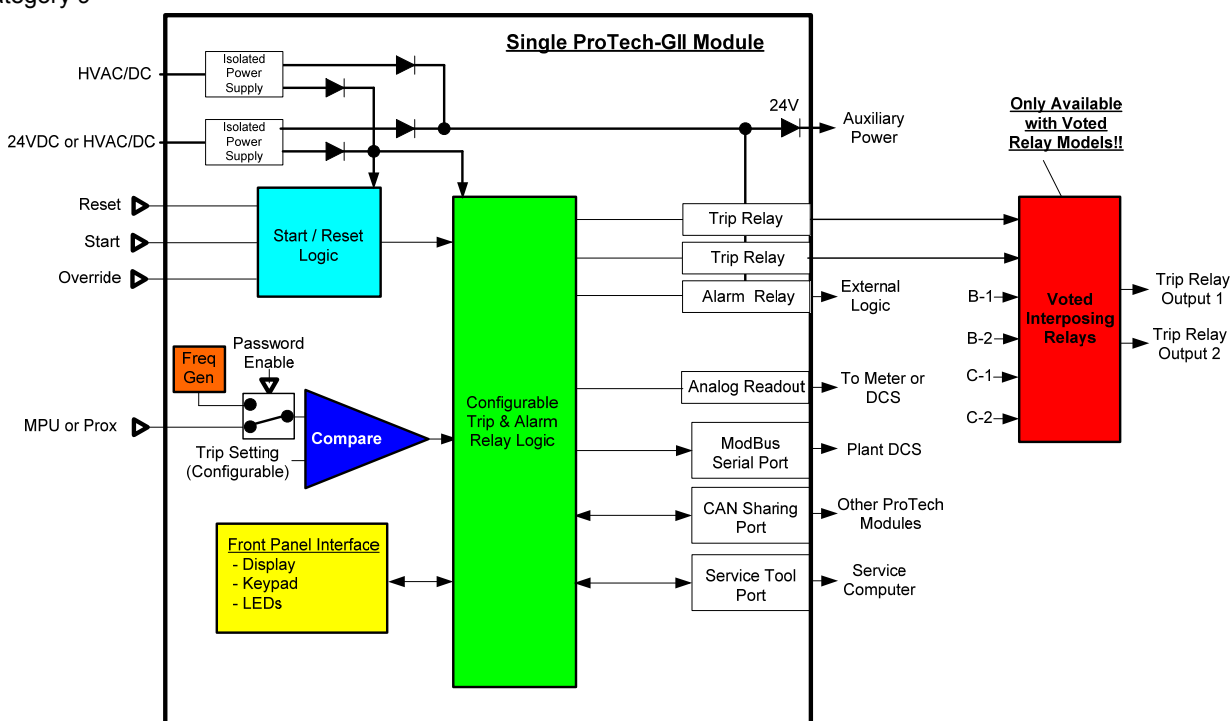

Single Module Functional Diagram

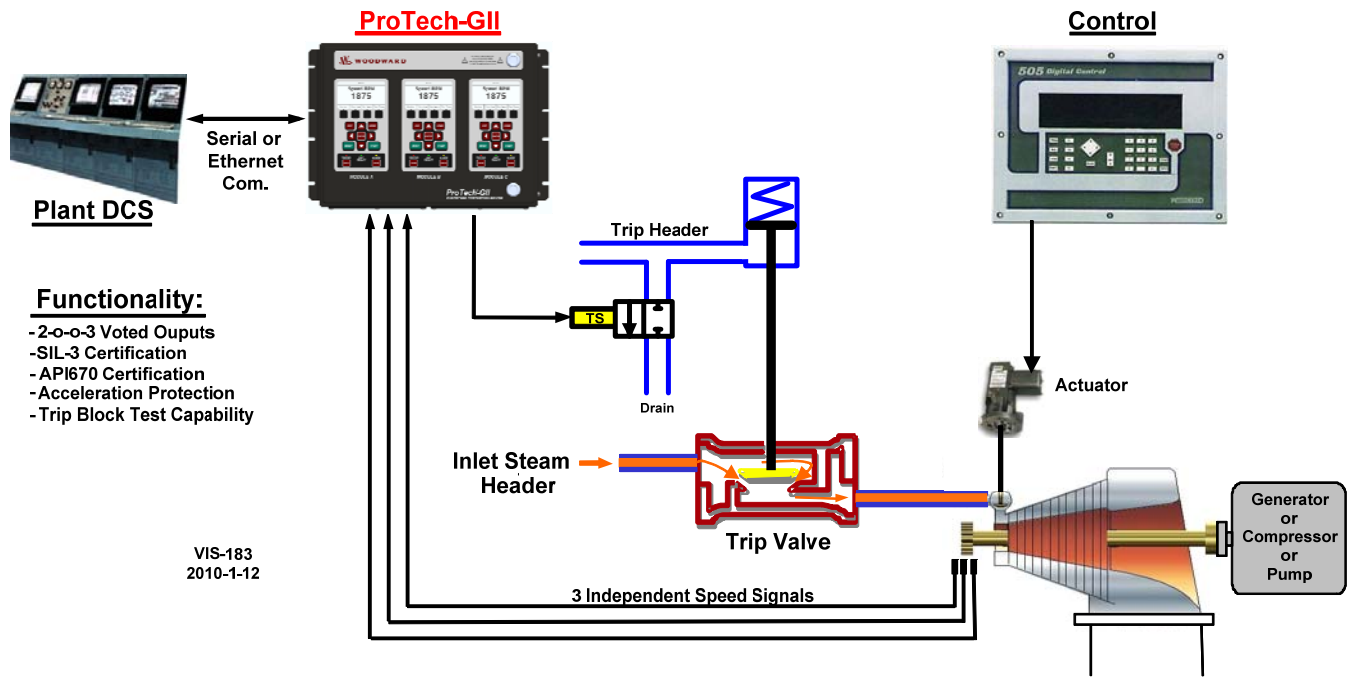

2-out-of-3 Voted Application Diagram

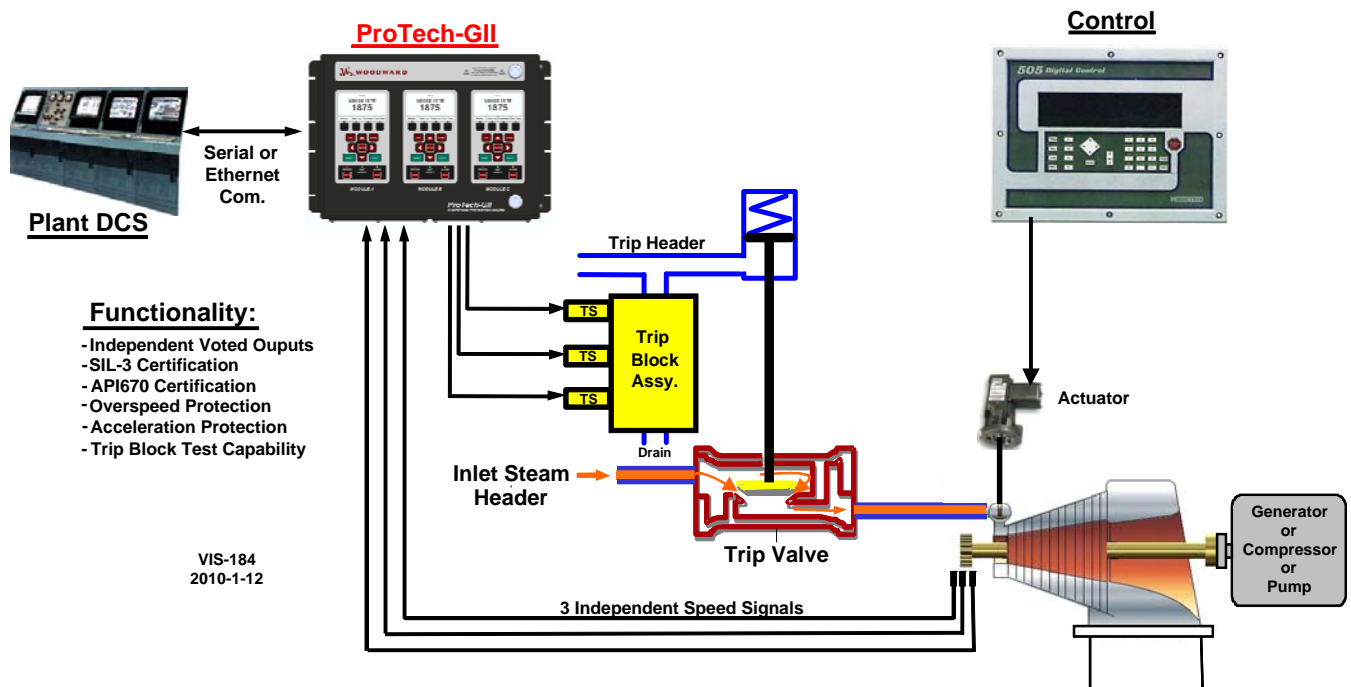

Independent Voted Application Diagram



PO Box 1519, Fort Collins CO, USA 80522-1519  
 1000 East Drake Road, Fort Collins CO 80525  
 Tel.: +1 (970) 482-5811 ♦ Fax: +1 (970) 498-3058  
[www.woodward.com](http://www.woodward.com)

**Distributors & Service**

Woodward has an international network of distributors and service facilities. For your nearest representative, call the Fort Collins plant or see the Worldwide Directory on our website.

This document is distributed for informational purposes only. It is not to be construed as creating or becoming part of any Woodward contractual or warranty obligation unless expressly stated in a written sales contract.

© Woodward 2009, All Rights Reserved

For more information contact: