



MFR 11

Multi Function Relay Protection

APPLICATIONS

The MFR 1 Series is a family of industrial grade protective relays that offer multiple protective features in a single package.

Using a digital processor to measure true RMS values enables a high degree of measuring accuracy regardless of harmonics, transients or disturbing pulses.

The MFR 11 model is a generator or mains protection unit packaged into one compact device. Typical applications are generators and switchgear equipment that require independent protection architecture. Different packages offer additional functionality.

The MFR 11/MP is for mains protection use with over-/undervoltage, -frequency and voltage asymmetry with 24 Vdc power supply while the MFR 11/NU has the same functions, but utilizes a wide-range power supply.

The MFR 11/VDEW adds phase/vector jump monitoring to the MP package. The MFR 11/G59 package adds df/dt (ROCOF) protection. The MFR 11/G59N has the same features as the G59 package, but utilizes the wide-range power supply.

The MFR 11/SC is used for synch-check and zero voltage detection to check whether two systems are synchronous or de-energized.

The compact size and multiple functions of the MFR 11 help to simplify switchgear design. The digital display offers a user-friendly interface to setup the unit as well as monitor the operation and display any alarms.

DESCRIPTION

Features (all versions)

- True RMS voltage
- Configurable trip/control set points
- Configurable delays for each alarm
- Two-line LC display

MFR 11/MP

- 24 Vdc power supply
- 3 configurable relays
- Over-/undervoltage monit. (59/27)
- Over-/underfrequency monit. (81O/U)
- Voltage asymmetry monitoring (47)

MFR 11/NU

Same features as MFR 11/MP, plus:

- Wide-range power supply (no 24 Vdc) (90 to 265 Vac/dc)

MFR 11/VDEW

Same features as MFR 11/MP, plus:

- Vector/phase shift monitoring (78)

MFR 11/G59

Same features as MFR 11/MP, plus:

- 8 configurable relays
- Vector/phase shift monitoring (78)
- df/dt ROCOF monitoring (81RL)

MFR 11/G59N

Same features as MFR 11/G59, plus:

- Wide-range power supply (no 24 Vdc) (90 to 265 Vac/dc)

MFR 11/SC

Same features as MFR 11/MP, plus:

- 2 configurable relays
- Synch-check (fixed to relay 3) (25)
- Zero voltage monitoring: dead bus start functionality (close CB to dead busbar)

MFR 11/SC+N

Same features as MFR 11/SC, but

- Wide-range power supply (no 24 Vdc) (90 to 265 Vac/dc)

- True RMS sensing
- Synch-check
- Programmable relay outputs
- Discrete inputs for enabling or remote acknowledgment
- PC and front panel configurable
- Microprocessor technology for accurate, repeatable and reliable operation
- Programmable threshold setpoints with individual time delays
- CE marked
- UL/cUL Listed
- GL Approval

SPECIFICATIONS

Accuracy Class 1
 Power supply 24 Vdc (18 to 30 Vdc)
 Packages NU / G59N / SC+N: 90 to 265 Vac/dc
 Intrinsic consumption max. 12 W
 Ambient temperature -20 to 70 °C
 Ambient humidity 95 %, non-condensing
Voltage Rated Δ/D : [1] 66/115 Vac [4] 230/400 Vac
 Maximum value (V_{max}): [1] 150 Vac [4] 300 Vac
 Rated voltage $V_{ph-ground}$: [1] 150 Vac [4] 300 Vac
 Rated surge voltage: [1] 2.5 kV [4] 4.0 kV
 Linear measuring range up to $1.3 \times V_{rated}$
 Measuring frequency 50/60 Hz (40 to 70 Hz)
 Input resistance [1] 0.21 MW, [4] 0.7 MW
 Max. power consumption per path < 0.15 W
Discrete inputs isolated
 Input range 18 to 250 Vac or dc
 Input resistance approx. 68 kW

Relay outputs isolated
 Contact material AgCdO
 Load (GP) 24 Vdc@2 Adc, 250 Vac@2 Aac
 Pilot duty (PD) 24 Vdc@1 Adc
Housing Type APRANORM DIN 43 700
 Dimensions 96×72×130 mm
 Front cutout 91×67 mm
 Connection screw/plug terminals depending on connector 1.5 mm² or 2.5 mm²
 Front insulating surface
 Protection system IP 21
 Weight depending on version, approx. 800 g
Disturbance test (CE) tested according to applicable EN guidelines
Listings UL/cUL listed (note: max. voltages apply) for ordinary loc., file E231544
Approvals GL (Germanischer Lloyd)

DIMENSIONS

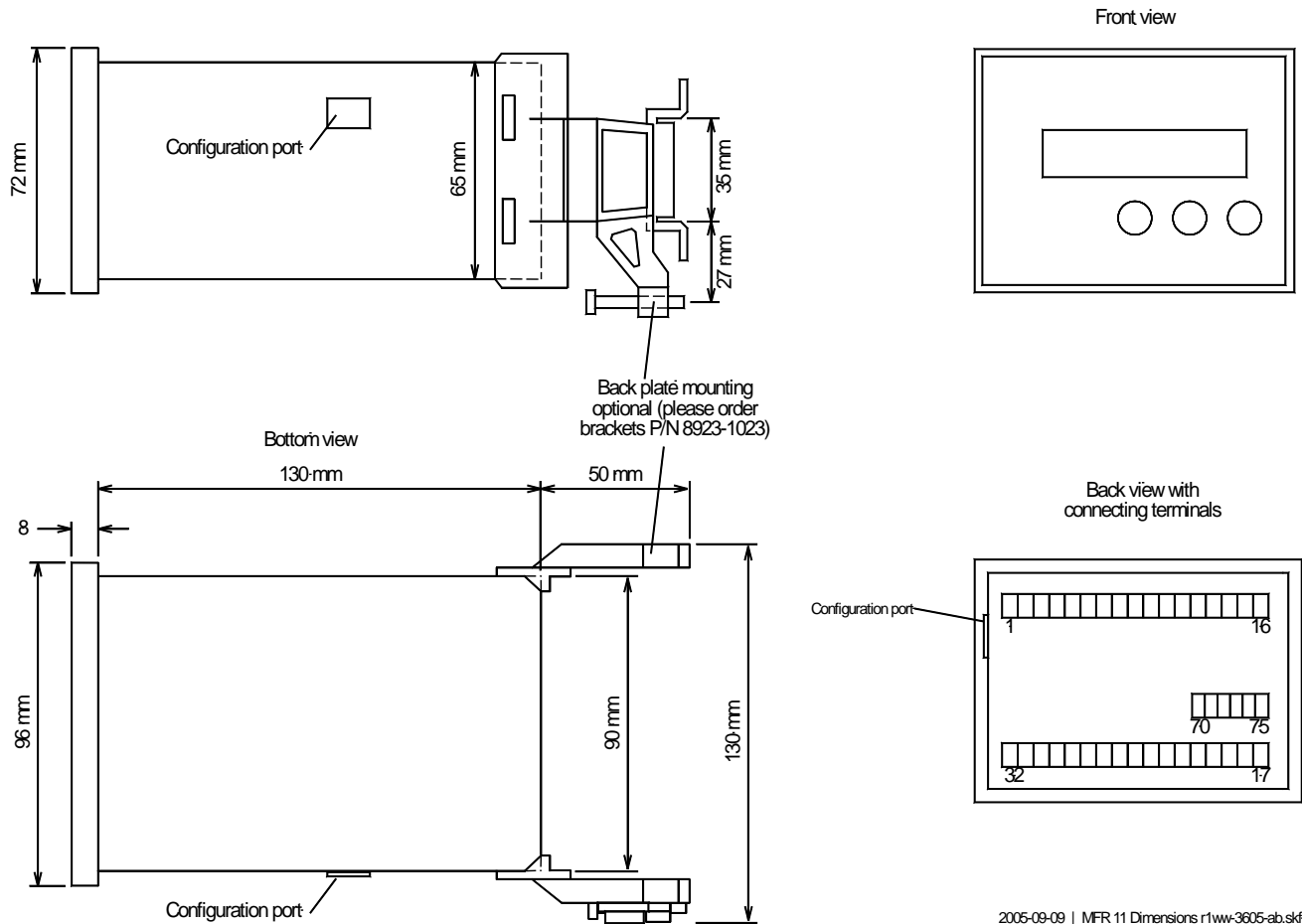

WIRING DIAGRAM

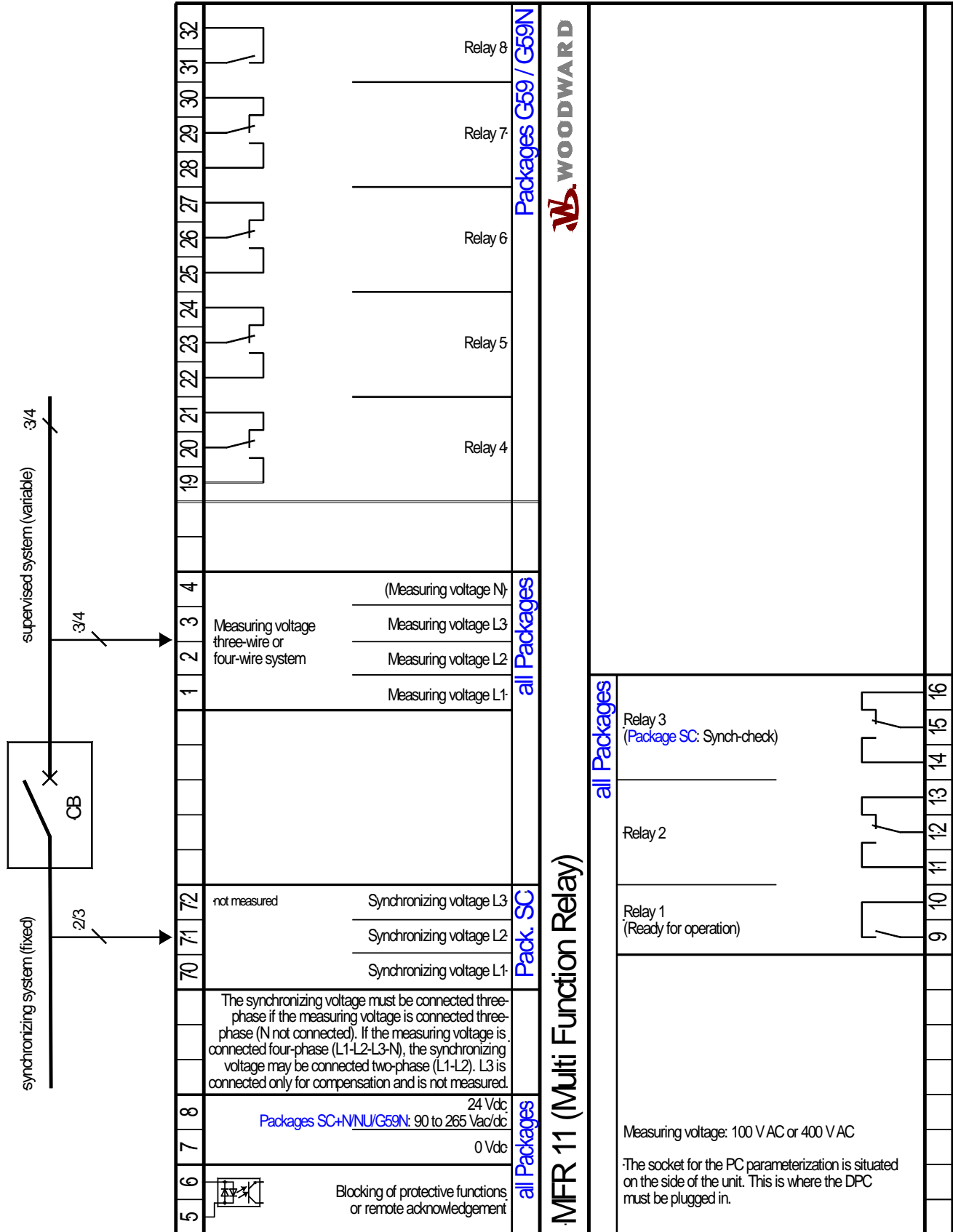

Subject to technical modifications.

International
 Woodward
 PO Box 1519
 Fort Collins CO, USA
 80522-1519
 1000 East Drake Road
 Fort Collins CO 80525
 Ph: +1 (970) 498-3634
 Fax: +1 (970) 498-3058
 email:
 SalesPGD_NAandCA@woodward.com

Europe
 Woodward GmbH
 Handwerkstrasse 29
 70565 Stuttgart, Germany
 Ph: +49 (0) 711 789 54-510
 Fax: +49 (0) 711 789 54-101
 email:
 SalesPGD_EMEA@woodward.com

Distributors & Service
 Woodward has an international network of distributors and service facilities. For your nearest representative, call the Fort Collins plant or see the Worldwide Directory on our website.

www.woodward.com

For more information contact:

Subject to technical modifications.

This document is distributed for informational purposes only. It is not to be construed as creating or becoming part of any Woodward Governor Company contractual or warranty obligation unless expressly stated in a written sales contract.

We appreciate your comments about the content of our publications. Please send comments including the document number below to stgt-doc@woodward.com

© Woodward

All Rights Reserved

03244E - 2012/6/Stuttgart

FEATURES OVERVIEW

		MFR 11						
ANSI		MP	NU	VDEW	G59	G59N	SC	SC+N
Measuring/Display								
Voltage		ü	ü	ü	ü	ü	ü	ü
Voltage (2 nd input for synch-check)							ü	ü
Accessories								
Configuration via PC #1		ü	ü	ü	ü	ü	ü	ü
Protection								
Overvoltage	59	ü	ü	ü	ü	ü	ü	ü
Undervoltage	27	ü	ü	ü	ü	ü	ü	ü
Overfrequency	81O	ü	ü	ü	ü	ü	ü	ü
Underfrequency	81U	ü	ü	ü	ü	ü	ü	ü
Voltage asymmetry	47	ü	ü	ü	ü	ü	ü	ü
vector/phase shift (dj /dt)	78			ü	ü	ü		
df/dt (ROCOF)	81RL				ü	ü		
Function								
Synch-check	25						ü	ü
Zero voltage monitoring: dead bus start (close CB to dead busbar)							ü	ü
I/O's								
Output relays (configurable)	74	3	3	3	8	8	3	3
Power Supply								
24 Vdc		ü		ü	ü		ü	
90 to 265 Vac/dc			ü			ü		ü
Listings/Approvals								
CE marked		ü	ü	ü	ü	ü	ü	ü
UL/cUL listed		ü		ü	ü		ü	
GL (Marine)		ü		ü	ü		ü	
Product Number P/N								
Measuring inputs 110 Vac		5448-884	LR20610	8441-1003	5448-885	8441-1004	8441-1005	8441-1110
Measuring inputs 400 Vac		8441-1023	8441-1027	8441-1049	LR20406	8441-1103	8441-1097	8441-1111

#1 Cable incl. software necessary (DPC, Product Number P/N 5417-557)

TYPICAL APPLICATIONS

MFR 11/MP

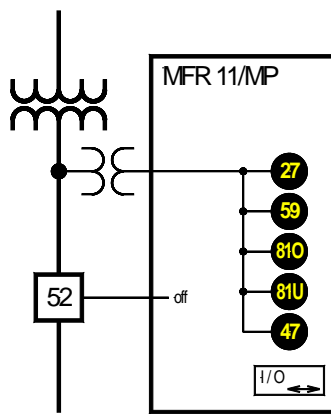

MFR 11/G59

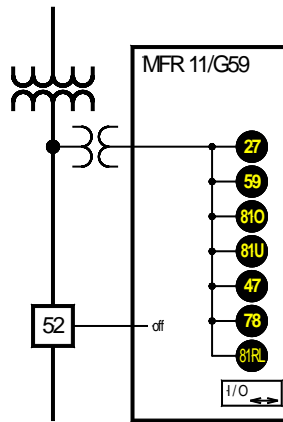

MFR 11/SC

