

SPC Servo Position Controller

Applications

The Servo Position Controller (SPC) is a servo-valve driver that accepts a DeviceNet™ * or (4 to 20) mA based position demand signal from a system controller, and accurately positions proportional or integrating servo-valves. The SPC has the required accuracy, responsiveness, and redundancy required for steam or gas turbine fuel valve control. For valve position sensing, the SPC accepts feedback signals from one or two (redundant) ac devices or one dc device.



A Windows based software program is used to configure the SPC, adjust tunables, and monitor parameters via a personal computer. For ease of service, SPC configurations can be done while connected or disconnected to the unit. Once a configuration has been created, this program allows configurations to be uploaded and downloaded to other SPCs as desired.

The SPC's position feedback circuit includes integral excitation and signal-conditioning circuitry for LVDT and RVDT based position sensing devices.

Description

The SPC is a field programmable servo-driver that controls one integrating or proportional servo-valve, and accepts single or dual feedback signals for valve position sensing.

This compact digital driver can be commanded (controlled) via a DeviceNet based network, and functions as a DeviceNet (Group II only) slave device on this network. As an alternative or backup to DeviceNet, a (4 to 20) mA input signal can be used to command servo position.

The SPC's associated PC interface software program allows a user to configure, auto-calibrate, dynamically adjust, and manually stroke the controlled servo. Auto-calibration routines make servo setup easy and greatly reduce installation times.

The SPC driver is classified for heavy industrial environments, and can be easily bulkhead mounted in IP20 locations.

Protection

The SPC includes protection and alarm indication for the following faults:

- DeviceNet Comm Time-out
- Feedback Open-Wire
- Position Error
- Actuator Open/Short
- Analog Input Out-of-Range
- Feedback Voltage Out-of-Range
- Internal SPC Faults
- Driver Overcurrent

A hard-wired shutdown contact input and relay driver output are provided to allow for interfacing with external protection circuits.

*—DeviceNet is a trademark of Open DeviceNet Vendor Association, Inc (ODVA)

- Fieldbus controlled (via DeviceNet)
- Field configurable
- Accepts redundant command signals
- Accepts redundant feedback signals
- Compatible with ac or dc feedback signals
- Includes LVDT or RVDT excitation circuitry
- (4 to 20) mA position readout
- Sulfur-resistant conformal coated
- Certified for Class I, Division 2, Groups A, B, C, D, T4 locations
- Certified for Zone 2, IIC, T4 locations
- CE compliant

Redundancy

Optionally the SPC can be configured to accept redundant position commands and redundant servo position feedback signals. The SPC has the capability to accept DeviceNet and 4–20 mA based position demand signals and upon the failure of either demand signal to switch to the healthy input demand signal. The SPC also has the capability to accept two servo position feedback signals and switch to the healthy feedback signal when one of the feedback signals fails.

Driver Specifications

Input Power:

24 V (dc) / (18 to 32) V (dc)

Actuator Drive Output (Configurable Options):

Bipolar Output with adjustable null current and the following configurable ranges:

±250 mA, ±100 mA, ±50 mA, ±25 mA, ±10 mA

Unipolar Output Current with the following configurable ranges:

(0 to 250) mA, (0 to 100) mA, (0 to 50) mA, (0 to 25) mA

Dither—Adjustable current amplitude at a frequency of 25 Hz, and a duty cycle of 25 %

Position Loop Accuracy:

DeviceNet Commanded: ±0.25 % of full scale at 25 °C, temperature sensitivity of less than ±150 ppm/°C

Analog (4 to 20) mA Commanded: ±0.25 % of full scale at 25 °C, temperature sensitivity of less than ±300 ppm/°C

Position Sensing (2 Channels):

Voltage Feedback: Accepts 3, 4, 5, or 6 wire LVDTs or RVDTs (single excitation driver), (0 to 12) V (dc), (12 to 0) V (dc)

Current Feedback: Accepts (4 to 20) mA, (20 to 4) mA position transducer feedback signals

Relay Driver Outputs (Alarm & Shutdown):

Isolated FETs designed for direct control connection with or without interposing relays

Voltage Range: (18 to 32) V (dc)

Max Current: 500 mA, (10 µA leakage)

ENVIRONMENTAL

Operating Temperature Range: (–40 to +70) °C

Shock: US MIL-STD-810C method 516.2, procedure 1 (30 Gs, 11 ms half sine pulse)

Vibration: Lloyd's Register Test Specification No.1, 1996, Vibration Test 1 (5 Hz to 13 Hz, ±1 mm, 13.2 Hz to 100 Hz, ±0.7 g)

Humidity: Lloyd's Register Test Specification No.1, 1996, Humidity Test (48 Hr Cyclic – Condensing)

Size: (330 x 203 x 76) mm / (13 x 8 x 3) inches

Mounting: Bulkhead mounted

Ingress Protection: IP20

Pollution Resistance

Particulate Pollution Resistance: IEC 664-1 Pollution Degree 2 (Normally only nonconductive pollution occurs. Temporary conductivity caused by condensation is to be expected.)

Gaseous Pollution Resistance: The polyacrylate conformal coating withstands NO₂, CO₂, SO₂, and H₂S gases per IEC 60068-2-60: 1995 Part 2.60 Method 1 and 4 (Flowing Mixed Gas Corrosion Test). It will withstand levels typical of telecommunications and computer installations as defined by Battelle Labs Class III (between IEC 60721-3-3 classification 3C1 and 3C2, light industrial to urban industrial, heavy traffic).

REGULATORY COMPLIANCE

European Compliance for CE Marking:

EMC Directive: 2004/108/EC

ATEX Directive: 94/9/CE LCIE 01 ATEX 6076 X, Zone 2, Category 3, Group II EEx nA II T4

North American Compliance

CSA: CSA Certified for Class I, Division 2, Groups A, B, C, & D, T4 at +70 °C ambient for use in the United States and Canada.

Other European and International Compliance:

GOST R: Certified for use in ordinary locations within the Russian Federation per GOST R certificate POCC US.MJ03.B00628.

Marine: (Models 8200-225 & 8200-226):

American Bureau of Shipping (ABS): Steel Vessel Rules 4-9-7/13, 1-1-4/7.7, 2007.

Det Norske Veritas (DNV): Rules for Classification of Ships, High Speed & Light Craft and Det Norske Veritas' Offshore Standards Temperature Class B, Humidity Class B, Vibration Class A and EMC Class B. Enclosure protection according to Rules to be provided upon installation on board.

Lloyd's Register: ENV1, ENV2 and ENV3 as specified in Test Specification No. 1, 1996.

Functional Block Diagram

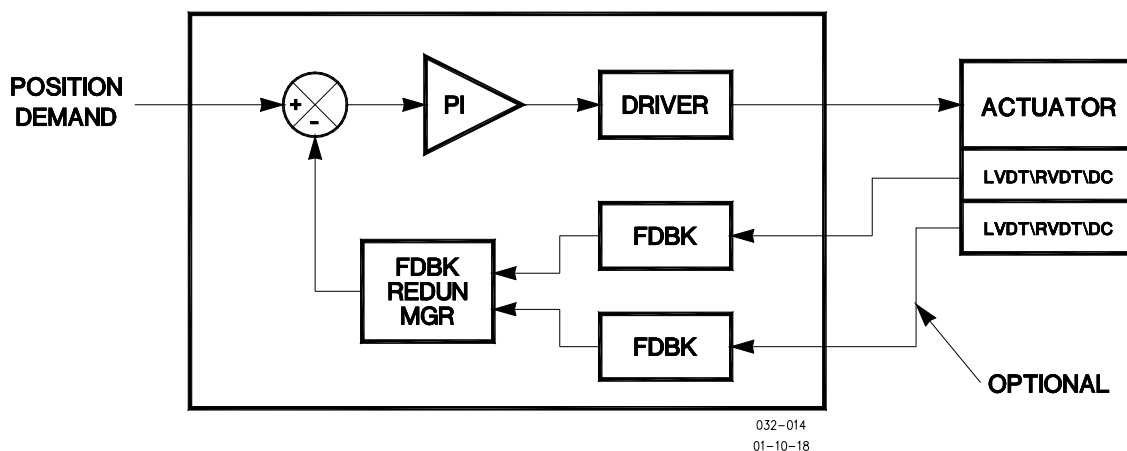

Typical Integrating Actuator Block Diagram

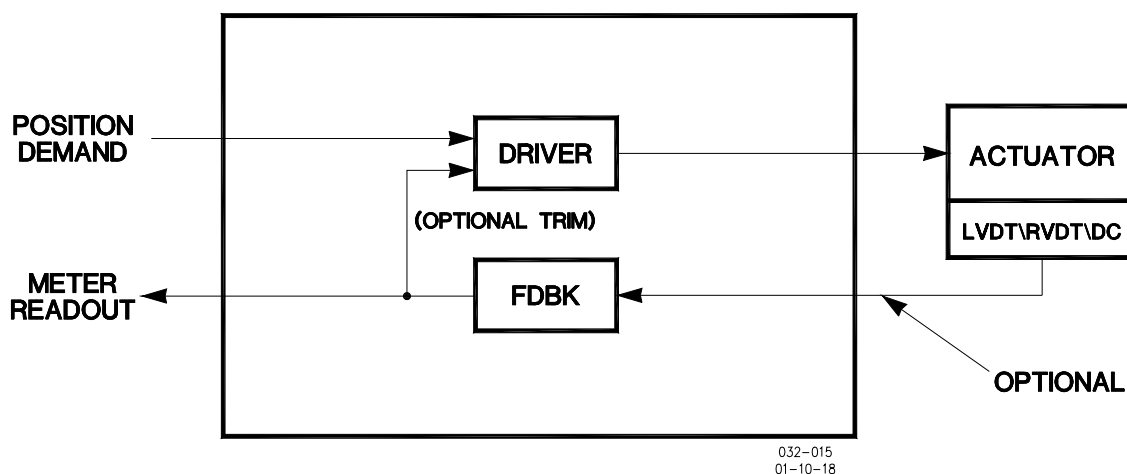

Typical Proportional Actuator Block Diagram

Wiring Diagram

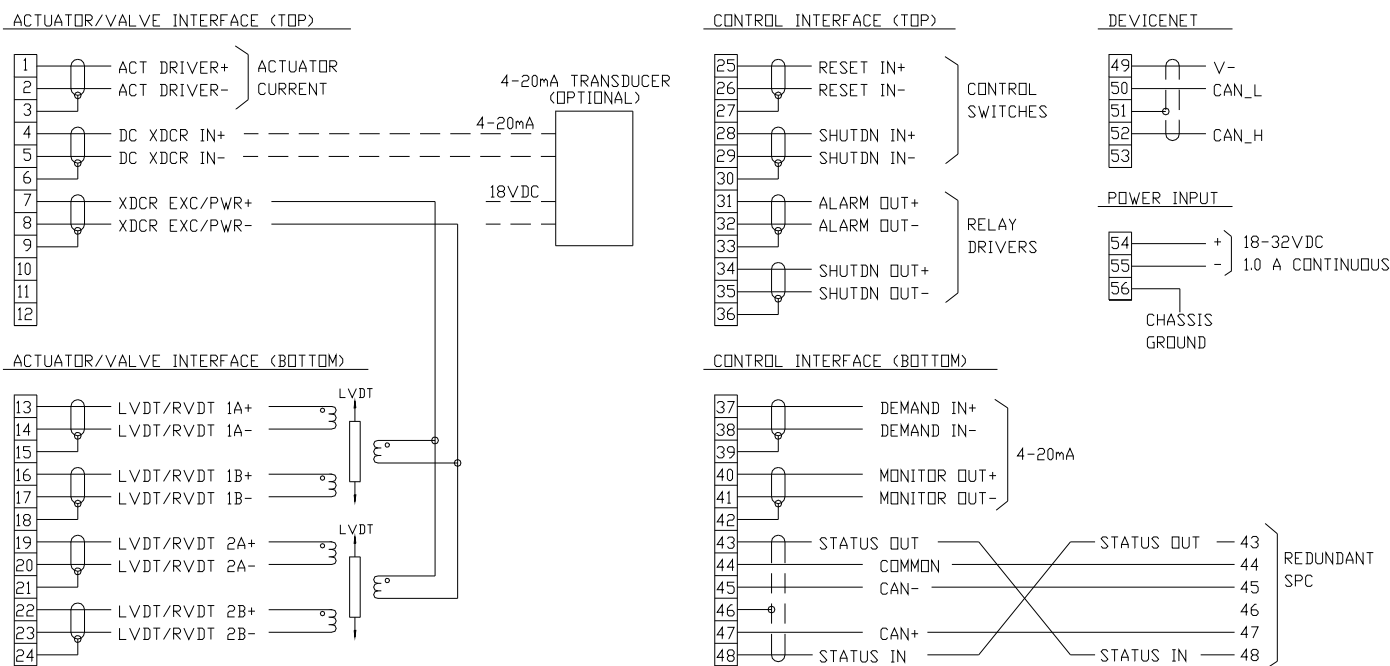

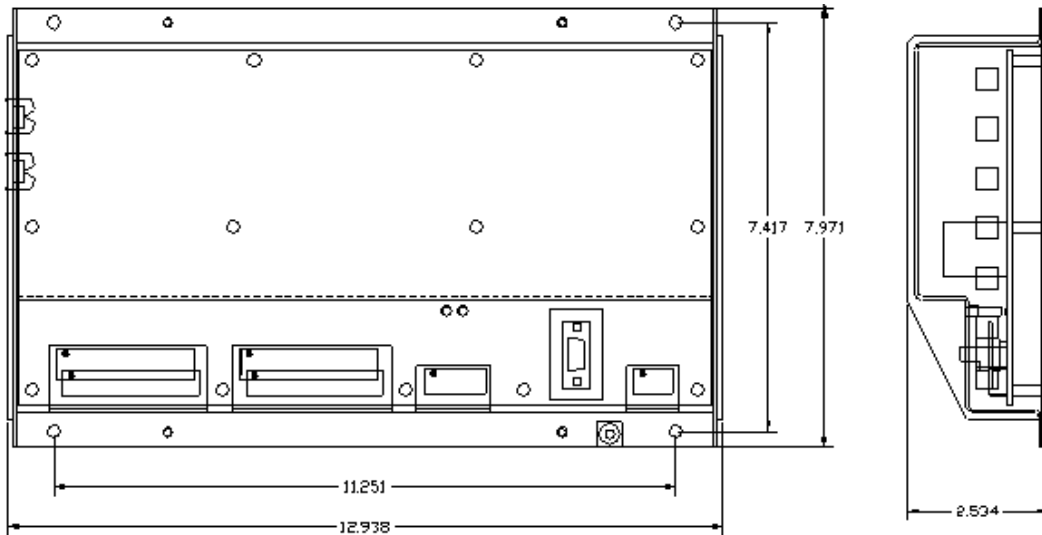

SPC Outline Drawing
(Do not use for construction)

Technical Manual 26236



PO Box 1519, Fort Collins CO, USA 80522-1519
1000 East Drake Road, Fort Collins CO 80525
Tel.: +1 (970) 482-5811 • Fax: +1 (970) 498-3058
www.woodward.com

Distributors & Service

Woodward has an international network of distributors and service facilities. For your nearest representative, call the Fort Collins plant or see the Worldwide Directory on our website.

This document is distributed for informational purposes only. It is not to be construed as creating or becoming part of any Woodward contractual or warranty obligation unless expressly stated in a written sales contract.

© Woodward 2001, All Rights Reserved

For more information contact:

2011/4/Colorado